

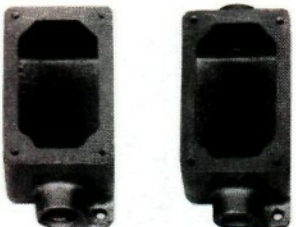

**Class I, Div. 1 and 2
Groups B, C, D
Class II, Div. 1 and 2,
Groups G
Class III
NEMA 7CD,9G**

U-Line® Mounting Boxes and U-Line Dimensions

Boxes Listed Not Suitable for Class I, Group B.

Type	Hub Size, Inches	Catalog Number	
		Malleable Iron	Aluminum
Single Gang			
 <p>Dead-End</p>	1/2	EFD150-NL-Q EFD175-NL-Q EFD110-NL-Q	EFD150A-NL-Q EFD175A-NL-Q EFD110A-NL-Q
	3/4		
	1		
 <p>Feed-Thru</p>	1/2	EFDC150-NL-Q EFDC175-NL-Q EFDC110-NL-Q	EFDC150A-NL-Q EFDC175A-NL-Q EFDC110A-NL-Q
	3/4		
	1		

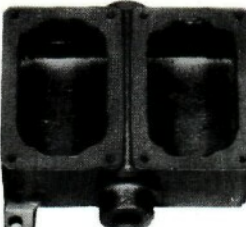
Two Gang			
 <p>Dead-End</p>	1/2	EFD250-NL-Q EFD275-NL-Q EFD210-NL-Q	EFD250A-NL-Q EFD275A-NL-Q EFD210A-NL-Q
	3/4		
	1		
 <p>Feed-Thru</p>	1/2	EFDC250-NL-Q EFDC275-NL-Q EFDC210-NL-Q	EFDC250A-NL-Q EFDC275A-NL-Q EFDC210A-NL-Q
	3/4		
	1		

Single Gang Box

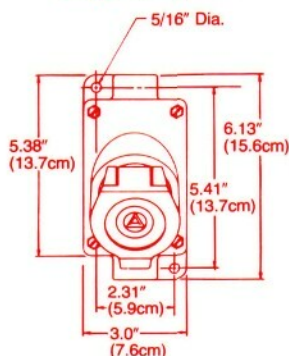

Two Gang Box

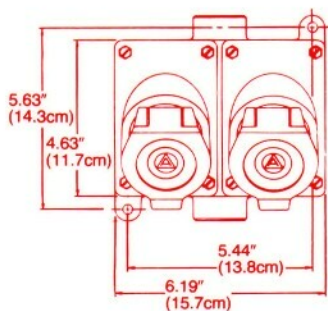

**U-Line Plugs
(15A, 125V illustrated)**

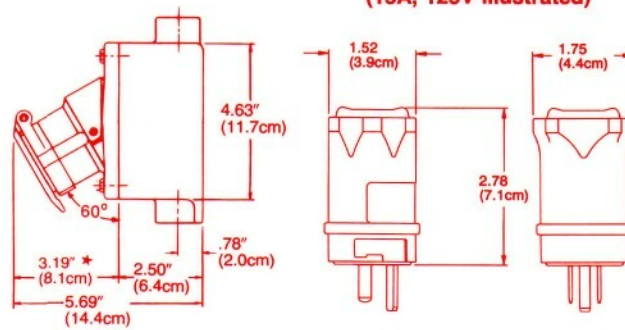

* Malleable Iron Receptacle: 3.38" (8.6cm)



Shaded area indicates items suitable for Class I, Group B in addition to Class I, Groups C and D.

N-8

Class I, Div. 1 and 2,
Groups C,D
Class II, Div. 1 and 2,
Groups E,F,G
Class III
NEMA 7CD,9EFG

EDS/EPS Mounting Bodies, Covers and Sealing Chamber/Switch Assemblies

Suffix — NL Indicates EFD Body without Switch Ears to Accommodate Sealing Chamber/Switch Assembly. Furnished with Internal Ground Screw.

	Hub Size, Inches	Dead-End Catalog Numbers		Feed-Thru Catalog Numbers	
		Malleable Iron	Aluminum	Malleable Iron	Aluminum
Single Gang, Two Gang and Tandem EFD Bodies					
Single Gang					
 Single Gang	1/2	EFD150-NL-Q	EFD150A-NL-Q	EFDC150-NL-Q	EFDC150A-NL-Q
	3/4	EFD175-NL-Q	EFD175A-NL-Q	EFDC175-NL-Q	EFDC175A-NL-Q
	1	EFD110-NL-Q	EFD110A-NL-Q	EFDC110-NL-Q	EFDC110A-NL-Q
Two Gang					
 Two Gang	1/2	EFD250-NL-Q	EFD250A-NL-Q	EFDC250-NL-Q	EFDC250A-NL-Q
	3/4	EFD275-NL-Q	EFD275A-NL-Q	EFDC275-NL-Q	EFDC275A-NL-Q
	1	EFD210-NL-Q	EFD210A-NL-Q	EFDC210-NL-Q	EFDC210A-NL-Q
Tandem					
 Tandem	1/2	EFDT50-NL-Q	—	EFDC250-NL-Q	—
	3/4	EFDT75-NL-Q	—	EFDC275-NL-Q	—
	1	EFDT10-NL-Q	—	EFDC210-NL-Q	—

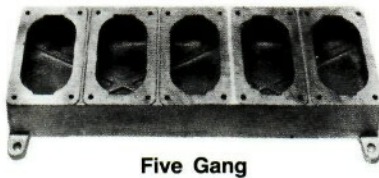



Five Gang

EFD Blank Bodies for Brazed Hubs

Gang	Cat. No.
1 Gang	EFD-1-NL
2 Gang	EFD-2-NL
3 Gang	EFD-3-NL
4 Gang	EFD-4-NL
5 Gang	EFD-5-NL

Construct complete catalog numbers per Cat. Sec. M, page 13A. Hubs will be located in center of walls and evenly spaced unless otherwise specified. Where spacings are critical, submit sketch showing exact spacing requirements.

	Switch Type	Catalog Number	
		20 Amp 120-277 Volt AC*	30 Amp 120-277 Volt AC**
 Front Cover/ Chamber/Switch Assembly	1-Pole 2-Pole 3-Way 4-Way	EDK-F21-Q EDK-F22-Q EDK-F23W-Q EDK-F24W-Q	EDK-F31-Q EDK-F32-Q EDK-F33W-Q —
 Rocker Cover/ Chamber/Switch Assembly	1-Pole 2-Pole 3-Way 4-Way	EDK-R21-Q EDK-R22-Q EDK-R23-Q EDK-R24W-Q	EDK-R31-Q EDK-R32-Q EDK-R33W-Q —

* 20A Switches 1 HP at 120 Volt A.C. and 2 HP at 240 Volt A.C. ** 30A Switches 2 HP at 120 or 240 Volt A.C.

Factory Sealed Control Stations and Pilot Lights: EFD and EDS Series. Explosion-Proof, Dust Ignition-Proof

UNILETS® for Use with Threaded Metal Conduit.

Features: EDS Push Buttons

- Factory sealed—eliminates need for adding sealing fittings and compound at each conduit entrance.
- Heavy duty, 10 ampere 600V rated.
- Switch is enclosed in separate sealing chamber.
- Sealing chamber has smooth, double flanges that mate both to cover and mounting enclosure to provide flame-tight joints.
- Pigtail leads from push buttons are factory sealed in sealing well.
- Stainless steel hex-head captive screws attach sealing chamber to cover and mounting enclosure.
- Side rocker arm push button has lockout holes.
- EFD back box supplied with internal ground screw.

Standard Materials

- *EFD control stations*: malleable iron body with aluminum cover.
- *SPB Push button*: aluminum upper barrel and phenolic lower barrel with lexan plastic button (Dust Cap models have neoprene buttons).
- *SPL pilot light*: aluminum guard and body assembly; steel clamping ring; and tempered glass jewel.
- *SSA selector switch*: aluminum operator mechanism, nylon cam, and sealed phenolic contact block.
- *EDS control stations*: malleable iron body and cover; aluminum sealing chamber; and nylon 6/6 operating handle.

Standard Finishes

- *EFD control stations*: body, triple-coat—(1) zinc electroplate, (2) dichromate, and (3) epoxy powder coat.
- *SPB push button, SPL pilot light and SSA selector switch*: natural finish.
- *EDS control stations*: body and cover, triple-coat—(1) zinc electroplate, (2) dichromate, and (3) epoxy powder coat sealing chamber, natural finish.

Options

- Three position selector switches with modified operation. Momentary contact right position, spring return to center, maintained contact left position. For description and switch diagram see page 33. Add suffix —**SR**.

- EFD selector switch Lockout—locks two- or three-position handle in any position. Suffix —**LD**.

- EFD push button Emergency STOP—front-operated red mushroom button. Suffix —**NMRB** (momentary contact).

- EFD pilot light jewel/guard assembly. Order by suffixes if color desired is other than red, as follows: Amber, —**JGB-A**; Blue, —**JGB-B**; Clear, —**JGB-C**; Green, —**JGB-G**; Opal, —**JGB-O**.

- EFD pilot light transformers for single pilot light per gang. Order by suffix:

Primary Voltage	Lamp Voltage	Suffix
220	120	—TR-2
277	120	—TR-3
440	120	—TR-4
550	120	—TR-5

- EFD and EDS units may be supplied with brazed hubs as 3, 4, and 5 gang in a variety of hub configurations. See Ordering Information page for how to order these and other "custom" units by adding suffixes to mounting body catalog numbers.

- Securing Rod for EFD Push Button Lockout Guard. Suffix —**SR**.

Compliances

- UL Standard 698.
- Class I, Div. 1 and 2; Class II, Div. 1 and 2. See listing pages for specific groups.
- Appleton malleable iron products conform to ASTM A47-77, Grade 32510, which has the following properties: tensile strength, 50,000 psi; yield, 32,000 psi; and elongation, 10%.
- Appleton aluminum products are produced from a high strength copper-free (4/10 of 1% max.) alloy.



EDS factory sealed rocker arm push button control station—shows separate sealing chamber and device construction.



Securing Rod for EFD Push Button Lockout Guard—available as an optional item as catalog number SBL-SR-Q (single guard only) or add Suffix —**SR** to push button catalog number. Lockout Guard, furnished as standard with the EFD push button, may also be padlocked.



EDS Rocker Arm Push Button has Hole for Lock.



SPBB factory sealed push button used in EFD Series—standard type and unit with dust cap.

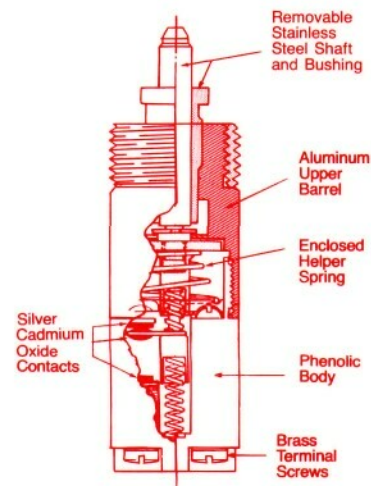

SPBB Design Features



**Class I, Div. 1 and 2,
Groups C,D
Class II, Div. 1 and 2,
Groups E,F,G
Class III
NEMA 7CD, 9EFG**
(Not suitable for Class I,
Group B)

Mounting Bodies for EFD and EDS Factory Sealed Control Stations

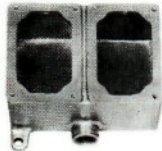
Provided Without Device Ears to Accommodate EDS Sealing Chamber/Device. Furnished with Internal Ground Screw.

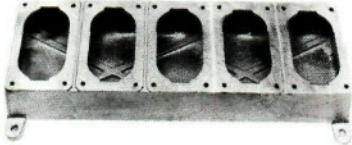
		Hub Size, Inches	Dead-End Catalog Numbers		Feed-Thru Catalog Numbers		
			Malleable Iron	Aluminum	Malleable Iron	Aluminum	
Single Gang, Two Gang, Tandem and Three Device Bodies							
 <p>Single Gang</p>	Single Gang—Deep						
	1/2	EFD150-NL-Q	EFD150A-NL-Q	EFDC150-NL-Q	EFDC150A-NL-Q		
	3/4	EFD175-NL-Q	EFD175A-NL-Q	EFDC175-NL-Q	EFDC175A-NL-Q		
	1	EFD110-NL-Q	EFD110A-NL-Q	EFDC110-NL-Q	EFDC110A-NL-Q		
 <p>Two Gang</p>	Two-Gang—Deep						
	1/2	EFD250-NL-Q	EFD250A-NL-Q	EFDC250-NL-Q	EFDC250A-NL-Q		
	3/4	EFD275-NL-Q	EFD275A-NL-Q	EFDC275-NL-Q	EFDC275A-NL-Q		
	1	EFD210-NL-Q	EFD210A-NL-Q	EFDC210-NL-Q	EFDC210A-NL-Q		
 <p>Tandem</p>	Tandem—Deep						
	1/2	EFDT50-NL-Q	—	EFDCT50-NL-Q	—		
	3/4	EFDT75-NL-Q	—	EFDCT75-NL-Q	—		
	1	EFDT10-NL-Q	—	EFDCT10-NL-Q	—		
 <p>Three Device</p>	Three Device—Deep						
	For use with EFKL Covers.						
	1/2	EFDL50-Q	—	EFDCL50-Q	—		
	3/4	EFDL75-Q	—	EFDCL75-Q	—		
	1	EFDL10-Q	—	EFDCL10-Q	—		
 <p>5 Gang</p>	Blank Bodies for Brazed Hubs						
	Deep—malleable iron						
	Gang	Cat. No.					
1 Gang	EFD-1-NL						
2 Gang	EFD-2-NL						
3 Gang	EFD-3-NL						
4 Gang	EFD-4-NL						
5 Gang	EFD-5-NL						
			Construct complete catalog number per page M-14. Hubs will be located in center of walls and evenly spaced unless otherwise specified. Where spacings are critical, submit sketch showing spacing requirements.				

Covers and Devices are listed on Pages 6,7,9 and 12. Accessories on Pages 10 and 11. Dimensions on Pages 16 and 17.