

STORAGE

Chests



2460



Optional casters available for increased mobility. See page 433 for options

- Recessed and concealed lock protectors for maximum security against drilling and cutting lock (Model 1332 and 1636 one lock protector only)
- Finger-groove lid handle for easy opening
- Convenient storage tray on back wall for small items (Models 2448, 2460, 2472, 3048)
- "X" models do not include rear tray for larger opening
- Heavy-duty piano hinges with non-removable pin
- Patented, ergonomically designed fold-down recessed handles
- Angled 3-1/2" high support skids feature threaded holes for easy caster installation
- Recommend #1 and #5 Master Lock® padlocks or equivalent
- Made in the USA

SPECIFICATIONS 1332 1636 2142 2448 2460 3048 2472

Capacity FT³	4.9	6.7	9.7	16.6	20.8	25	25
Weight	78 lbs. (35 kg)	101 lbs. (46 kg)	124 lbs. (56 kg)	159 lbs. (72 kg)	184 lbs. (83 kg)	200 lbs. (91 kg)	214 lbs. (97 kg)

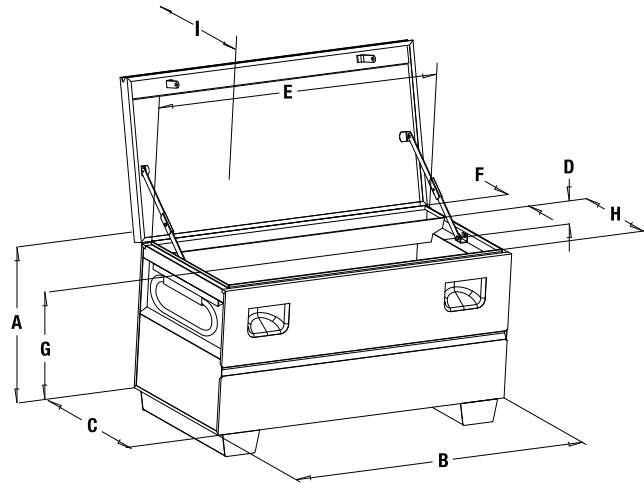

DIMENSIONS

	A	B	C	D	E	F	G	H	I
1332	14"	32"	19"	—	29.5"	—	—	—	16.75"
1636	17"	36"	19"	—	33.5"	—	—	—	16.75"
2142	20"	42"	20"	—	39.5"	—	—	—	17.75"
2448	25"	48"	24"	4"	45.5"	4"	19"	15.5"	21.75"
2448X	25"	48"	24"	—	45.5"	—	—	15.5"	21.75"
2460	25"	59"	24"	4"	57.5"	4"	19"	15.5"	21.75"
2460X	25"	59"	24"	—	57.5"	—	—	15.5"	21.75"
3048	30"	48"	30"	4"	45.5"	4"	24"	21.5"	27.75"
3048X	30"	48"	30"	—	45.5"	—	—	21.5"	27.75"
2472	25"	72"	24"	4"	69.5"	4"	19"	15.5"	21.75"
2472X	25"	72"	24"	—	69.5"	—	—	15.5"	21.75"

CAT. NO.	UPC NO.	DESCRIPTION
1332	38717	Storage chest without tray
1636	38718	Storage chest without tray
2142	31651	Storage chest without tray
2448	23273	Storage chest
2448X	00852	Storage chest without tray
2460	23363	Storage chest
2460X	00858	Storage chest without tray
3048	23362	Storage chest
3048X	00859	Storage chest without tray
2472	07483	Storage chest
2472X	00853	Storage chest without tray

Welder's Boxes



- Protects small tools and supplies and comes with a single lock hasp for use with padlock
- Compact side handles for easy portability
- Heavy-duty hinges, plus chain connector to hold lid in open position
- Recommend #1 and #5 Master Lock® padlocks or equivalent
- Made in the USA

SPECIFICATIONS	1230	1531
Capacity FT ³	3.3	4.8
Height	12"	15"
Width	30"	31"
Depth	16"	18"
Weight	42 lbs. (19 kg)	52 lbs. (24 kg)

CAT. NO.	UPC NO.	DESCRIPTION
1230	31510	Welder's box
1531	23274	Welder's box

Replacement Parts

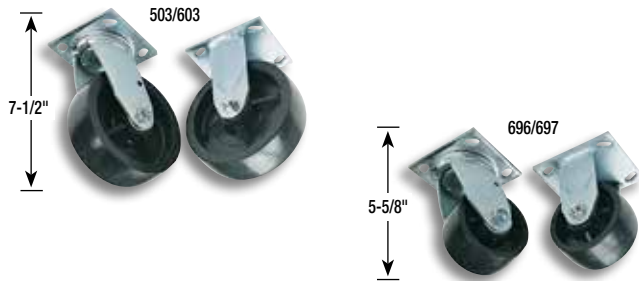

- Caster bolt pattern 2-7/8" x 3-1/4"
- Polyolefin-injected molded hard casters: stain-resistant, chemical-resistant and non-marking

SPECIFICATIONS	503	603	703	696	697
Diameter	6 in. (152 mm)	6 in. (152 mm)	6 in. (152 mm)	4 in. (102 mm)	4 in. (102 mm)
Tread	2 in. (51 mm)	2 in. (51 mm)	2 in. (51 mm)	2 in. (51 mm)	2 in. (51 mm)
Capacity	2000 lbs. (907 kg)	2000 lbs. (907 kg)	2000 lbs. (907 kg)	1600 lbs. (726 kg)	1600 lbs. (726 kg)
Ship Weight	22 lbs. (10 kg)	20 lbs. (9 kg)	20 lbs. (9 kg)	13 lbs. (6 kg)	15 lbs. (7 kg)

CASTER SELECTION CHART

STORAGE BOX CAT. NO.	CASTER CAT. NO.			
	503	603	703	696
1332	✓	✓	✓	✓
1636	✓	✓	✓	✓
2142	✓	✓	✓	✓
2448	✓	✓	✓	✓
2460	✓	✓	✓	✓
3048	✓	✓	✓	✓
2472	✓	✓	✓	✓
1230				
1531				
5060MESH	✓	✓	✓	Included
3360	✓	✓	✓	✓
4848	✓	✓	✓	✓
4860	✓	✓	✓	✓
4872	✓	✓	✓	✓
2260	✓	✓	✓	✓
3648	✓	✓	✓	✓
3660	✓	✓	✓	✓
5660L	✓	✓	✓	✓
5660LH	✓	✓	✓	✓
5760TD	✓	✓	✓	✓
5860	Included	Included	✓	
3548	✓	✓	Included	
8060DLX	✓	✓	✓	✓

CAT. NO.	UPC NO.	DESCRIPTION
503*	28044	4 Swivel
603*	23405	2 Rigid, 2 Swivel
703†	08420	2 Rigid, 2 Locking Swivel
696*	15341	2 Rigid, 2 Swivel
697*	89189	4 Swivel
52025978	20965	Lid Support – (L) Side
52025979	20966	Lid Support – (R) Side
08428	08428	10 mm Gas Spring Ball Stud Replacement Kit (all Slant/Flat-Tops)
53950	53950	Gas Springs for 2260 only
53951	53951	Gas Springs for 3360 only
08427	08427	13 mm Gas Spring Ball Stud Replacement Kit (8060 DLX)
55294	55294	Replacement Gas Spring Kit – Shock and (2) Clips (8060 DLX)
01886	01886	Replacement Gas Spring Kit for 4872, 4848, 4860, 3648 & 3660

* Each caster set includes (16) 3/8-16 x 1" self-threading mounting screws.
 † Each caster set includes (16) 3/8-16 x 1" carriage bolts; (16) 3/8-16 hex nuts; (16) 3/8 lockwashers.
 Note: Screw/washer kit p/n 50062913 is necessary for mounting 703 casters on boxes other than 3548.